

1. Scope of Application

These specifications apply to chip type LED lamp, CITILED, model CL-654-C1D.

2. Part code

CL- 654 - C1 D

Series _____
 654 : White power LED for general lighting

Watt Class _____
 C1 : 1 watt package

Lighting color _____
 D : White color rank D (around CCT 6300K)

			Approved	Checked	Drawn	Symbol	CITILED
						Name	CL-654-C1D
						Drawing No	
Mark	Date	Description	Appro.	CITIZEN ELECTRONICS CO.,LTD.			

3. Outline drawing

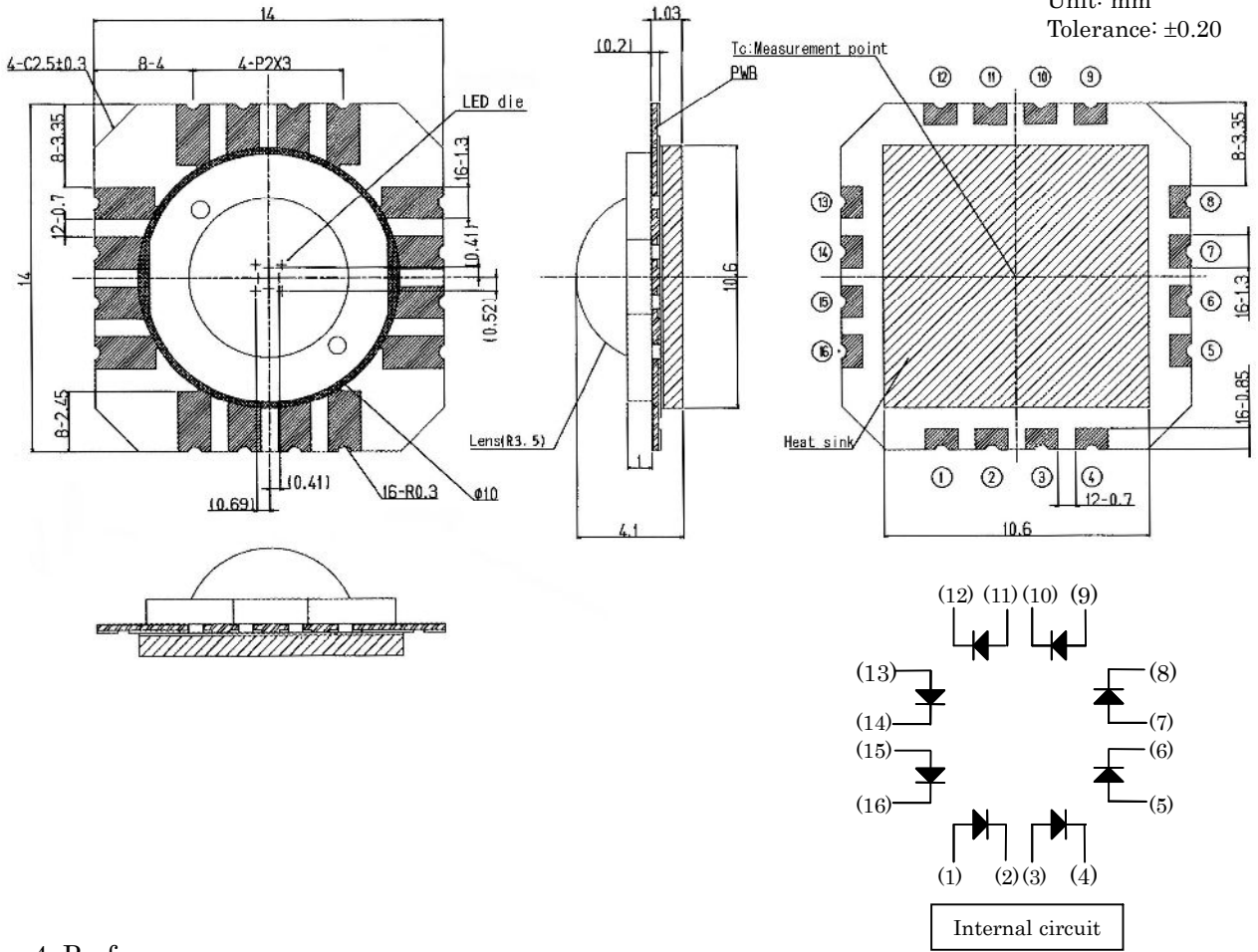

4. Performance

(1) Absolute Maximum Rating

Parameter	Symbol	Rating Value	Unit
Power Dissipation	Pd	2.0	W
Forward Current *1	IFDC	480	mA
Forward Pulse Current *2	IFP	800	mA
Reverse Voltage *3	VR	5	V
Operating Temperature	Top	-25 ~ +80	°C
Storage Temperature	Tst	-30 ~ +85	°C
Junction Temperature*4	TjMax	120	°C

- *1 The value is based on 8-dice performances in parallel drive.
- *2 The value is based on 8-dice performances in parallel drive.
Duty ≤ 1/10, Pulse width ≤ 10 msec
- *3 The values is based on 1-die performance.
- *4 DC Current: $T_j = T_c + R_{j-c} \times P_d$
Pulse Current : $T_j = T_c + R_{j-c} \times P_w$ (Power Dissipation / one pulse)

(2) Thermal resistance: $R_{j-c}=10^{\circ}\text{C}/\text{W}$

			Approved	Checked	Drawn	Symbol	CITILED
						Name	CL-654-C1D
						Drawing No	
Mark	Date	Description	Appro.	CITIZEN ELECTRONICS CO.,LTD.			

(3) Electro-optical Characteristics

(Tc=25°C)

Parameter	Symbol	Condition	MIN	TYP	MAX	Unit
Forward Voltage *1	V _F	I _F =350mA	—	3.45	4.1	V
Reverse Current *2	I _R	V _R =5V	—	—	100	μA
Luminous Intensity *3	I _v	I _F =350mA	26.1	33.7	—	cd
Total Luminous Flux *1,4	Φ _v	I _F =350mA	(70.2)	(93)	—	lm
Chromaticity coordinates *1,5	x,y	I _F =350mA	※ See below			

*1 The values are based on 8-dice performances in parallel drive.

*2 The values are based on 1-die performance.

*3 In accordance with NIST standard. The values are based on 8-dies performance.

*4 Measurement condition :

Integrating sphere (Labsphere, 10inch), Sample position (spherical center)

*5 Chromaticity coordinates is the area surrounded with a,b,c,d.

Note 1) The tolerance of Forward Voltage measurement is ±3% at our tester.

Note 2) The tolerance of Luminous Intensity measurement is ±10% at our tester

Note 3) The tolerance of Chromaticity coordinates measurement is ±0.01 at our tester

• Chromaticity Coordinates Rank

	DR1		DR2	
	x	y	x	y
a	0.303	0.333	0.315	0.345
b	0.301	0.342	0.314	0.356
c	0.314	0.356	0.331	0.373
d	0.315	0.345	0.331	0.360

	DR3		DR4	
	x	y	x	y
a	0.307	0.316	0.317	0.327
b	0.303	0.333	0.315	0.345
c	0.315	0.345	0.331	0.360
d	0.317	0.327	0.331	0.340

	DR5		DR6	
	x	y	x	y
a	0.310	0.302	0.310	0.302
b	0.307	0.316	0.301	0.342
c	0.317	0.327	0.331	0.373
d	0.319	0.311	0.331	0.322

Color D Ranking Structure(x,y)

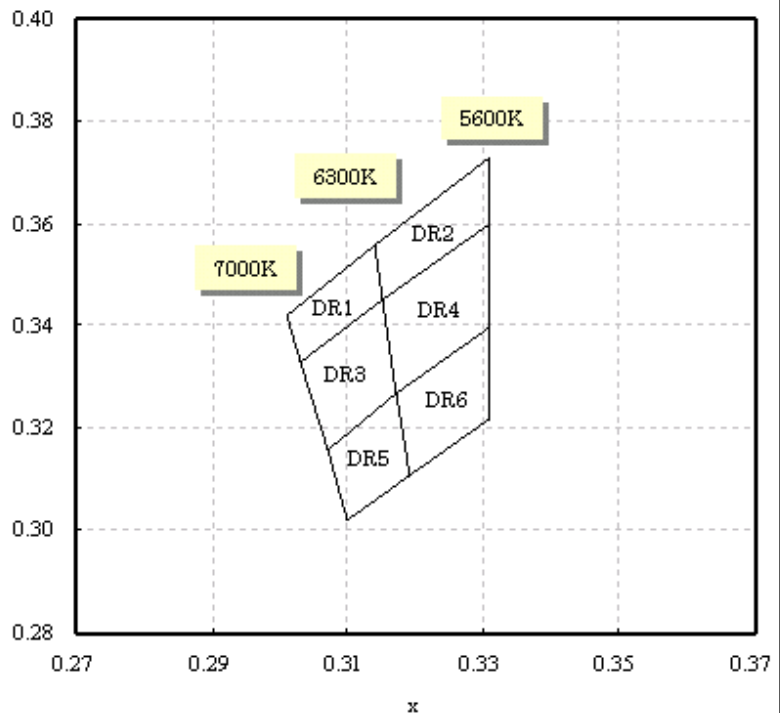

			Approved	Checked	Drawn	Symbol	CITILED
						Name	CL-654-C1D
						Drawing No	
Mark	Date	Description	Appro.	CITIZEN ELECTRONICS CO.,LTD.			

5. Characteristics

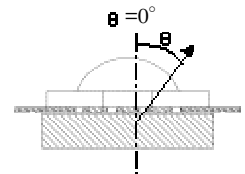
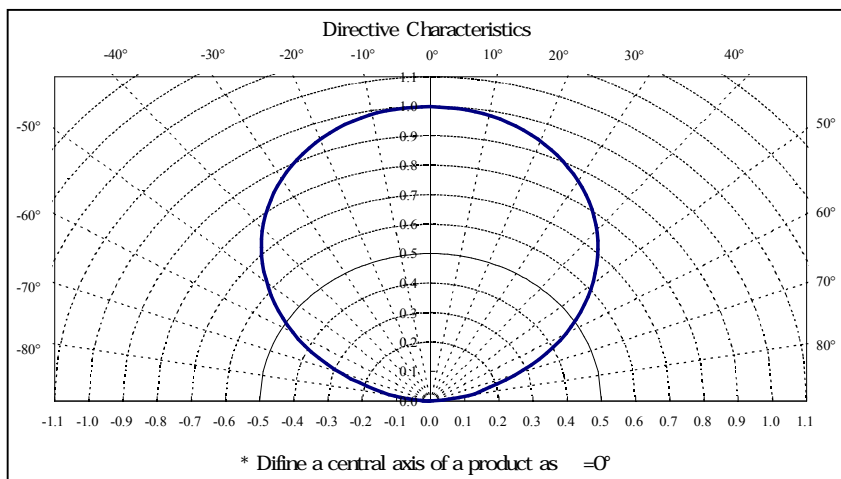
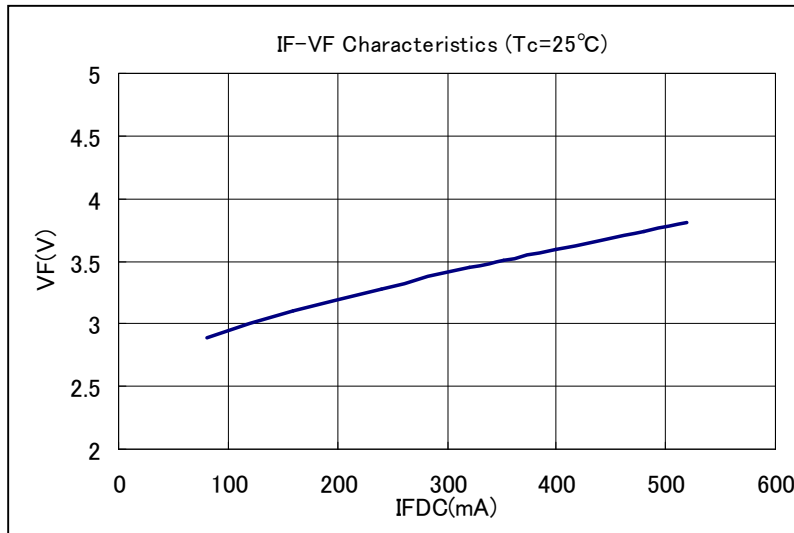
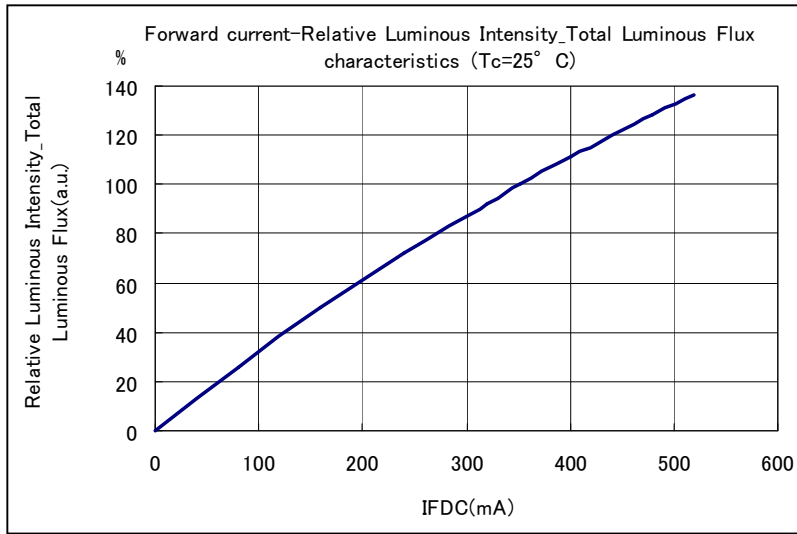

			Approved	Checked	Drawn	Symbol	CITILED
						Name	CL-654-C1D
						Drawing No	
Mark	Date	Description	Appro.	CITIZEN ELECTRONICS CO.,LTD.			

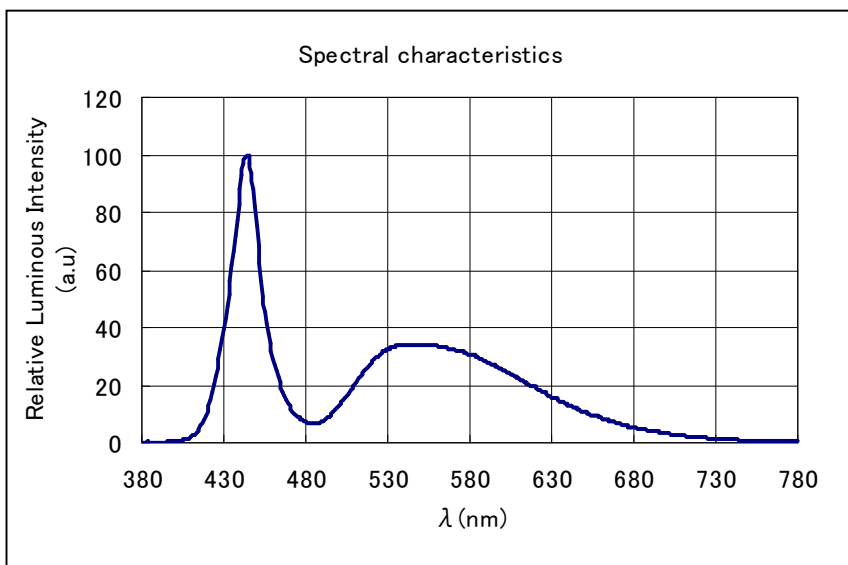
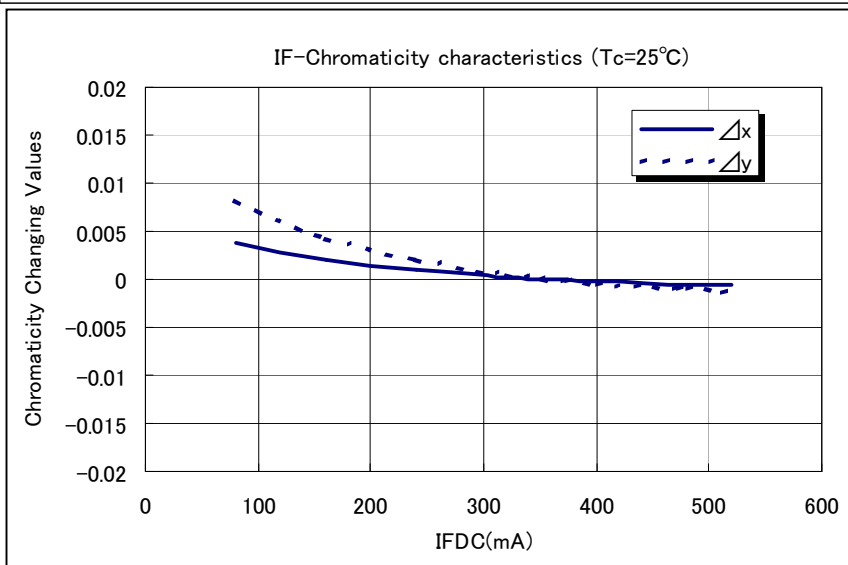
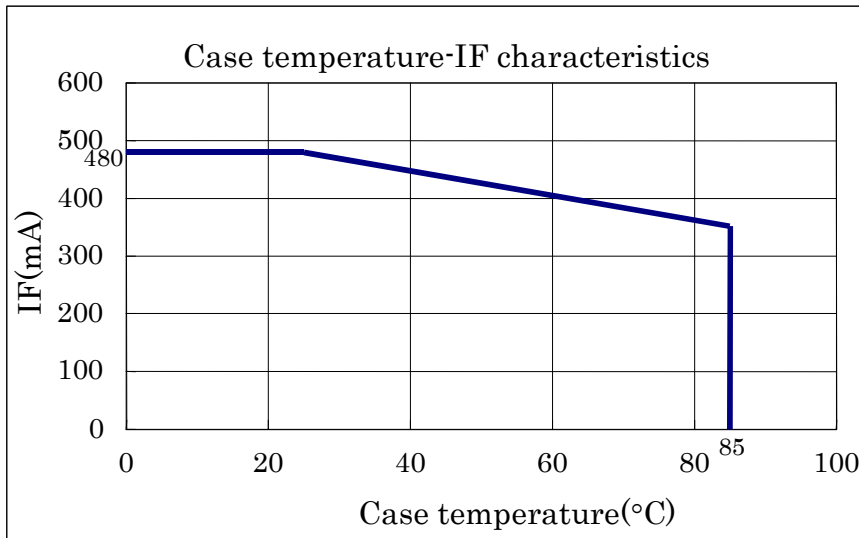

			Approved	Checked	Drawn	Symbol	CITILED
						Name	CL-654-C1D
						Drawing No	
Mark	Date	Description	Appro.	CITIZEN ELECTRONICS CO.,LTD.			

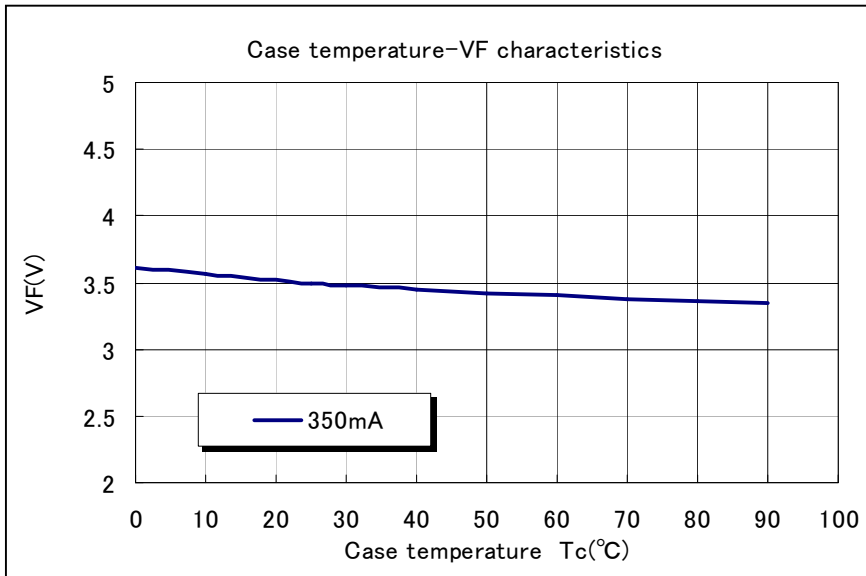
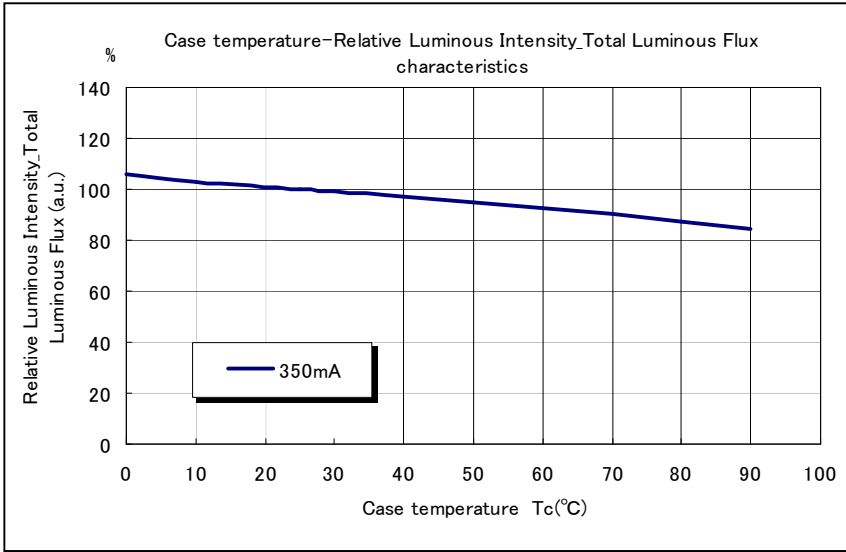

			Approved	Checked	Drawn	Symbol	CITELED
						Name	CL-654-C1D
						Drawing No	
Mark	Date	Description	Appr.	CITIZEN ELECTRONICS CO.,LTD.			

6. Reliability

(1) Details of the tests

Test Item	Test Condition
Life Test in Continuous Operation	Ta=25°C(Tj=70°C), I _F =44mA *1 × 1000 ⁺²⁴ ₋₁₂ hours Ta= 0°C(Tj=31°C), I _F =44mA *1 × 1000 ⁺²⁴ ₋₁₂ hours Ta=90°C(Tj=120°C), I _F =44mA *1 × 1000 ⁺²⁴ ₋₁₂ hours
Low Temperature Storage Test	-30 ⁺³ ₋₅ °C × 1000 ⁺²⁴ ₋₁₂ hours
High Temperature Storage Test	85 ⁺⁵ ₋₃ °C × 1000 ⁺²⁴ ₋₁₂ hours
Moisture-proof Test	60 ±2°C, 90 ±5%RH for 1000 ⁺²⁴ ₋₁₂ hours
Thermal Shock Test	-30°C × 30 minutes - 85°C × 30 minutes, 100-cycle
Solder Heat Resistance Test	Recommended temperature profile (reflow soldering) × 1

*1 The value is based on serial drive usage. (Nearly equal to 350mA on parallel drive usage.)

(2) Judgment Criteria of Failure for Reliability Test

(Ta=25°C)

Measuring Item	Symbol	Measuring Condition	Judgment Criteria for Failure
Forward Voltage	V _F	I _F =44mA *1	>U×1.1
Reverse Current	I _R	V _R =5V	>U×2
Luminous Intensity	I _V	I _F =44mA *1	<S×0.7

*1 The value is based on serial drive usage. (Nearly equal to 350mA on parallel drive usage.)

“U” defines the upper limit of the specified characteristics. “S” defines the initial value.

Note: Measurement shall be taken between 2 hours and 24 hours, and the test pieces should be returned to the normal ambient conditions after the completion of each test.

			Approved	Checked	Drawn	Symbol	CITELED
						Name	CL-654-C1D
						Drawing No	
Mark	Date	Description	Appro.	CITIZEN ELECTRONICS CO.,LTD.			

7. Taping Specifications (in accordance with JIS standard)

(1) Shape and Dimensions of Reel

(Unit: mm)

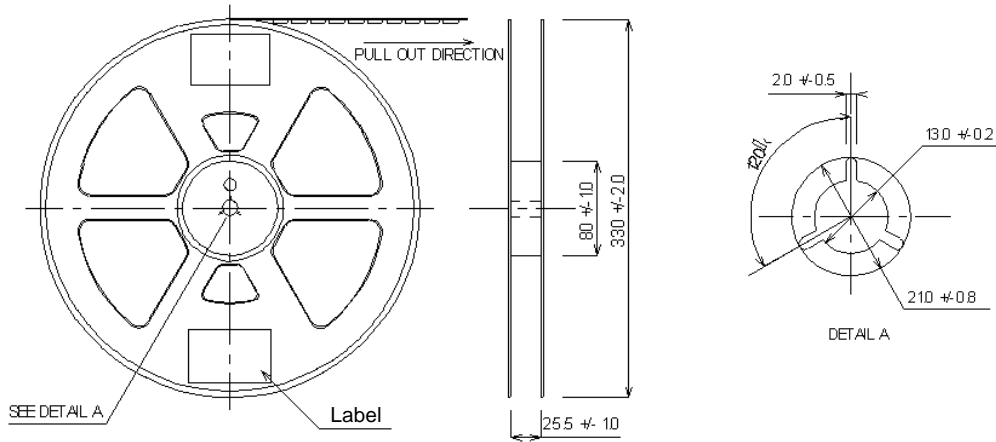

(2) Dimensions of Tape

(Unit: mm)

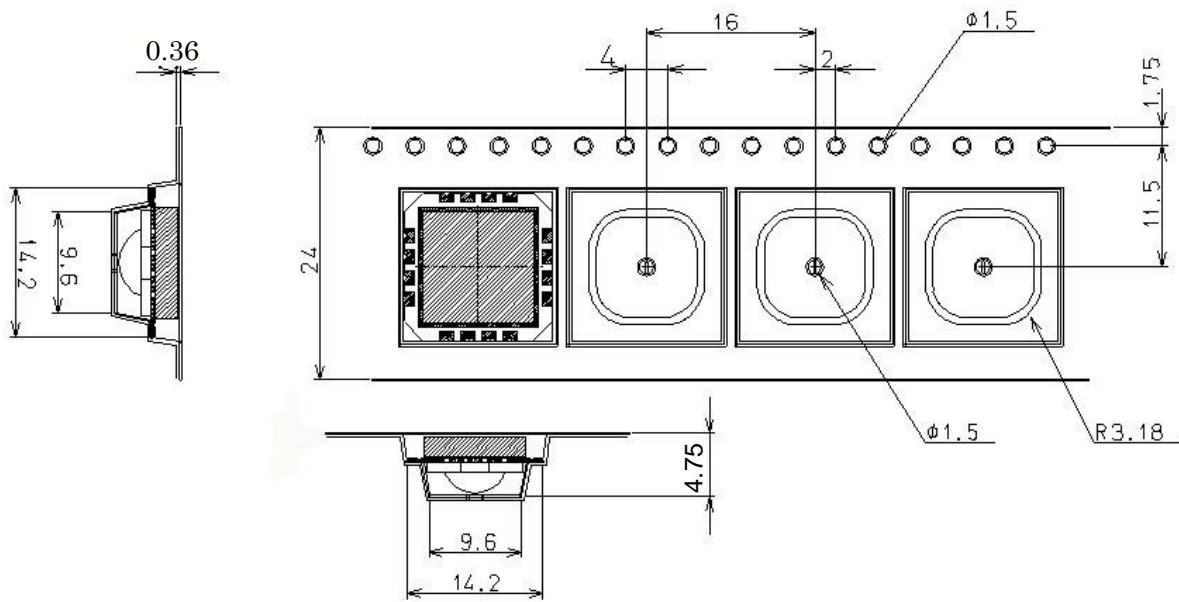

(3) Configuration of Tape (800pcs/Reel)

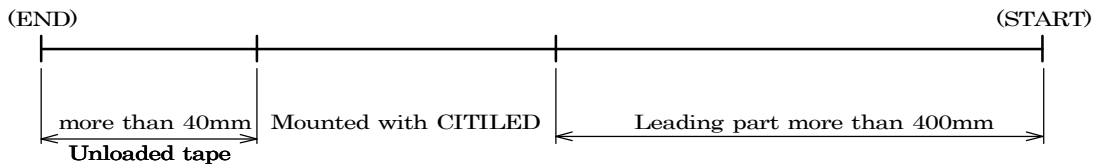

			Approved	Checked	Drawn	Symbol	CITILED
						Name	CL-654-C1D
						Drawing No	
Mark	Date	Description	Appro.	CITIZEN ELECTRONICS CO.,LTD.			

8. Packing Specifications

8-1. Moisture-proof Packing

To prevent moisture absorption during transportation and storage, reels are packed in aluminum envelopes which contain a desiccant with a humidity indicator.

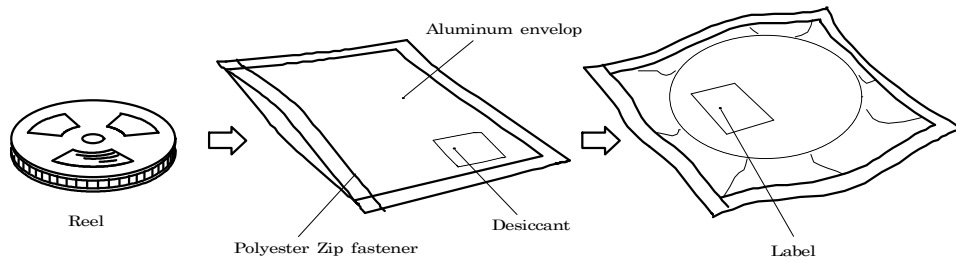

8-2. Storage

To prevent moisture absorption, it is strongly recommended that reels (in bulk or taped) should be stored in the dry box (or the desiccator) with a desiccant as the appropriate storage place. If not, the following is recommended.

Temperature: 5 ~ 30 °C
 Humidity: 60%RH max.

The devices should be mounted as soon as possible after unpacking. If you store the unpacked reels, please store them in the dry box or seal them into the envelop again.

8-3. Baking

If the devices have been stored over 6 months or unpacked over 7days, it should be baked under the following conditions.

Baking conditions: 60°C × 12 hours or more (reeled one)
 100°C × 45 minutes or more (loose one)
 150°C × 15 minutes or more (loose one)

			Approved	Checked	Drawn	Symbol	CITELED
						Name	CL-654-C1D
						Drawing No	
Mark	Date	Description	Appro.	CITIZEN ELECTRONICS CO.,LTD.			

9. Precautions

9-1. Soldering

(1) Manual soldering

- 1) Use 6/4 solder or solder containing silver (Ag)
- 2) Before soldering every time, make baking to units. By manual soldering, it is the possibility of crack due to the moisture absorption in the resin portion.
- 3) Use a soldering iron of 25W or smaller. Adjust the temperature of the soldering iron below 300°C.
- 4) Force or stress must not be applied to the resin portion while soldering.
- 5) Finish soldering within 3 seconds.
- 6) Handle the devices only after temperature is cooled down.

(2) Reflow soldering

- 1) The temperature profile at the top surface of the parts is recommended as shown below.
- 2) It is requested that products should be handled after their temperature has dropped down to the normal room temperature.

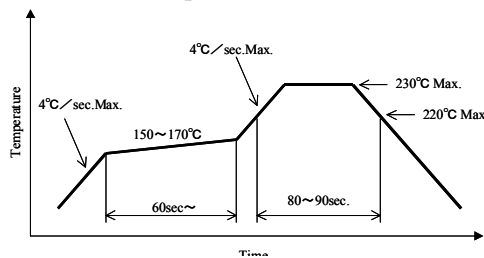

9-2. Handling

- (1) It is requested to avoid any stress added to the lens portion.
- (2) It is requested to avoid any friction by sharp metal nail etc. to the lens portion.
- (3) Please be aware that this product should not come into contact with any other parts in assembled status.
- (4) - Please take measures to prevent any static electricity being produced such as the wearing of a wristband or anti-static gloves when handling this product.
- As for damages due to static electricity, please check them by lighting inspection.

CE's lighting inspection criterion

Condition	Judgmental criterion
IF=0.3mA/die	No-lighting should not exist.

9-3. Other

- (1) This product complies with RoHs directives.
- (2) This product is intended for the application in general electronic devices (such as office automation equipment, communication devices, audio-video equipment, home electrical appliances, measurement hardware and others).
In cases where this product is used for the applications that requires high reliability or could directly affect human life or health due to failure or malfunction (aerospace hardware, medical equipment, atomic control equipment and others), please consult with our sales representatives beforehand.
- (3) Our warranty does not cover situations where this product undergoes secondary fabrication such as changes in shape.
- (4) An agreement of formal product specifications is required prior to mass production.
- (5) The specifications and appearance of this product are subject to change without advanced notice.

			Approved	Checked	Drawn	Symbol	CITELED
						Name	CL-654-C1D
						Drawing No	
Mark	Date	Description	Appr.	CITIZEN ELECTRONICS CO.,LTD.			

10. Designing precautions

(1) Drive circuit

- A constant current circuit is recommended as a drive circuit.
And when two or more LED packages are connected, the series connection between each package is recommended.
- Please design a circuit that prevents any reverse voltage (excess current) from being applied to this product instantaneously when the circuit is ON or OFF.

(2) Recommended soldering pattern

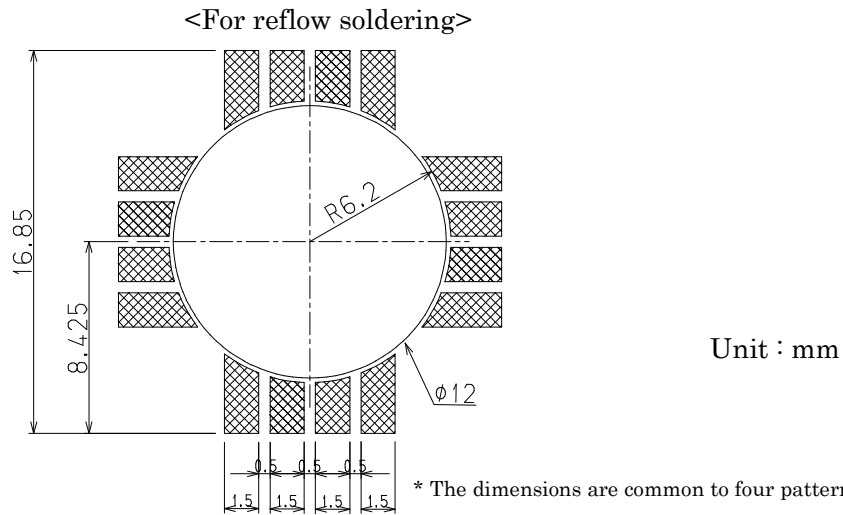

The above dimensions are not the one which guarantee the performance of mountability. The use of the above pattern is recommended to use after deep study at your site.

(3) When assembling the circuit board into the finished products, care must be taken to avoid the component parts from touching other parts.

(4) Thermal design

- As the LED package itself does not have any effective heat release feature, an outer heat sink shall be connected to the package's heat sink prior to usage as shown in the figure below for proper heat dissipation. It is recommended that attachment material such as heat radiating grease, heat transfer gel sheet and others is used between the package's heat sink and outer heat sink to increase adhesion.
- Please ensure that heat generation is not in excess of the absolute maximum rating.
- Factors responsible for an increase in temperature include heat generation attributed to ambient temperature conditions or power dissipation. Thus, drive conditions should be taken into consideration, depending on ambient temperature (Ta).

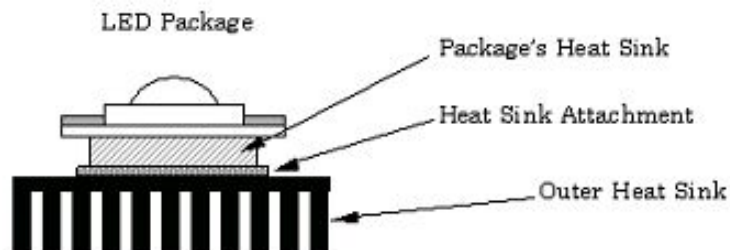

			Approved	Checked	Drawn	Symbol	CITELED
						Name	CL-654-C1D
						Drawing No	
Mark	Date	Description	Appro.	CITIZEN ELECTRONICS CO.,LTD.			