

Ring Backlighting Unit

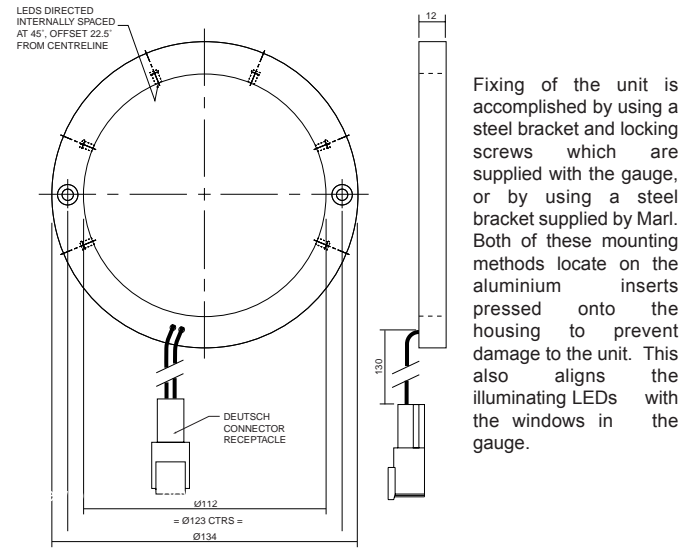

Technical Specification

Part Number	Colour	Voltage DC Vopr	Current DC Iopr	Power	Chromaticity Coordinates		Weight	Operating Temp Topr	Storage Temp Tstg	Connection
					x	y				
087-994-22-51	White	24	40	1.0	0.31	0.32	75	-30 to 60	-30 to 60	Deutch 2 way connector type DT04
087-994-25-59	White	110	7	0.8	0.31	0.32	75	-30 to 60	-30 to 60	2 way AMP connector
Units		V	mA	W			g	°C	°C	

Crescent Backlighting Unit

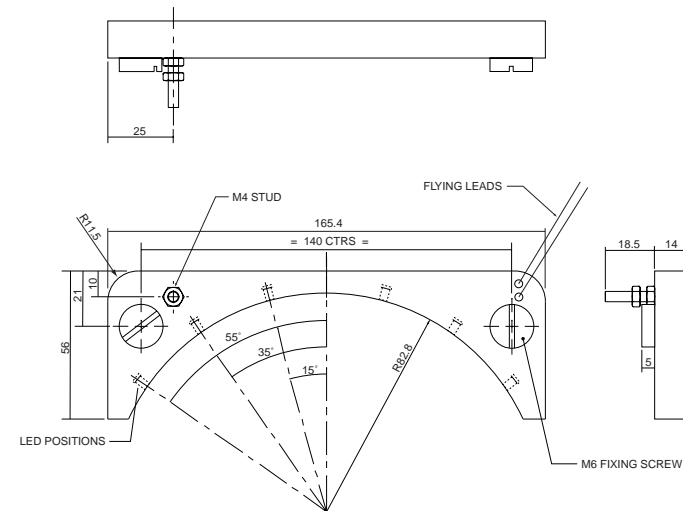

Technical Specification

Part Number	Colour	Voltage DC Vopr	Current DC Iopr	Power	Chromaticity Coordinates		Weight	Operating Temp Topr	Storage Temp Tstg	Connection
					x	y				
087-994-23-51	White	28	38	1.1	0.31	0.32	150	-30 to 60	-30 to 60	280mm flying leads with M5 ring crimps
087-994-25-50	White	110	7	0.8	0.31	0.32	150	-30 to 60	-30 to 60	400mm flying leads with M4 ring crimp on negative lead
087-994-25-54	White	110	7	0.8	0.31	0.32	150	-30 to 60	-30 to 60	400mm flying leads with M4 ring crimp on negative lead and additional M4 threaded stud to assist wiring to the vehicle
Units		V	mA	W			g	°C	°C	

Square Backlighting Unit

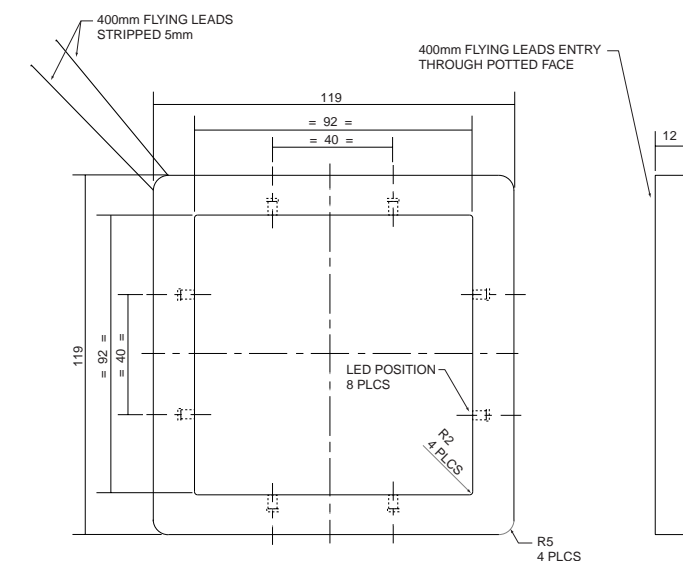
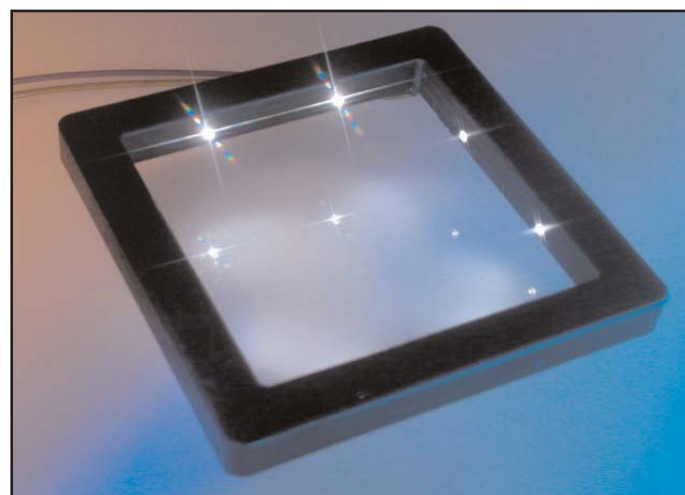

Technical Specification

Part Number	Colour	Voltage DC Vopr	Current DC Iopr	Power	Chromaticity Coordinates		Weight	Operating Temp Topr	Storage Temp Tstg	Connection
					x	y				
087-994-23-50	White	28	40	1.1	0.31	0.32	130	-30 to 60	-30 to 60	400mm flying leads supplied with M5 ring crimps
Units		V	mA	W			g	°C	°C	