

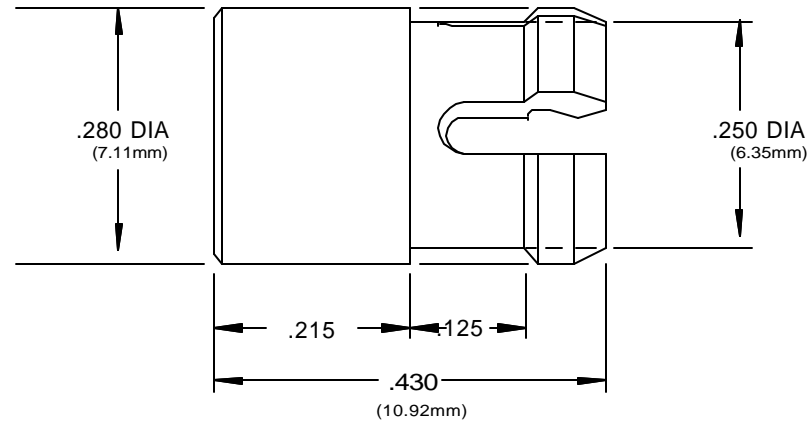

ACTUAL SIZE

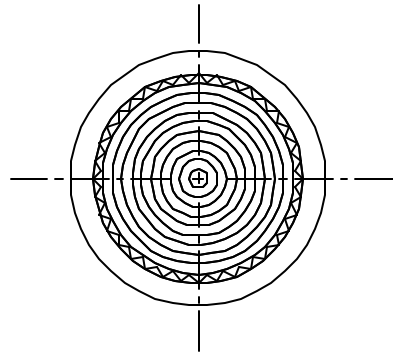

RECOMMENDED LED
SIZE T-1 3/4

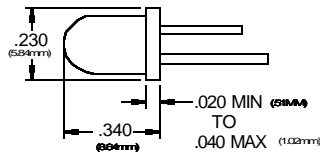

ORDERING CODES

MODEL CLF 280 RTP
COLOR _____

RTP Red Transparent BTP Blue Transparent
ATP Amber Transparent YTP Yellow Transparent
GTP Green Transparent CTP Clear Transparent

NOTES:

Material: Polycarbonate
UL Rating: "Thermoplastic material used on a secondary circuit".

Design: Low profile lens using fresnel rings and striated lines.

Mounting: Mounts thru the front of panel. Mounting holes should be deburred but not chamfered.
Hole size - .250 ±.002 (6.35mm) hole on 3/8" centers
Panel thickness 1/16" to 1/8"
For panel less than 3/16", SPC spacer is available
Standard metal or plastic washer can be used to increase panel thickness if necessary.

U.S. & Foreign Pat. Issued & Pend.

REVISIONS			
NO	DESCRIPTION	DATE	BY
1			
2			
3			
4			
5			

CLIPLITE[®] CLF 280

VCC VISUAL COMMUNICATIONS COMPANY, INC.
7920-F Arjons Drive San Diego, California 92126 U.S.A.
Phone (858) 549-6900 Fax (858) 549-3520 e-mail vccsales@vcclite.com

TOLERANCES	SCALE	5 X	DATE	10/25/95	DRAWING NO.
DECIMAL ±.010	DIAMETER	.003 TIR	DRAWN BY	JMS	CLF280A
ANGLE ± 30'	RADII	.008 Max	CHK'D		